

# NSC SQUARE/PYLON OVERVIEW

## MOCKUP BY DAY



\*SIZES SHOWN ON THE MOCKUPS ARE AN ESTIMATE

## MOCKUP BY NIGHT



\*SIZES SHOWN ON THE MOCKUPS ARE AN ESTIMATE

## MEASUREMENTS

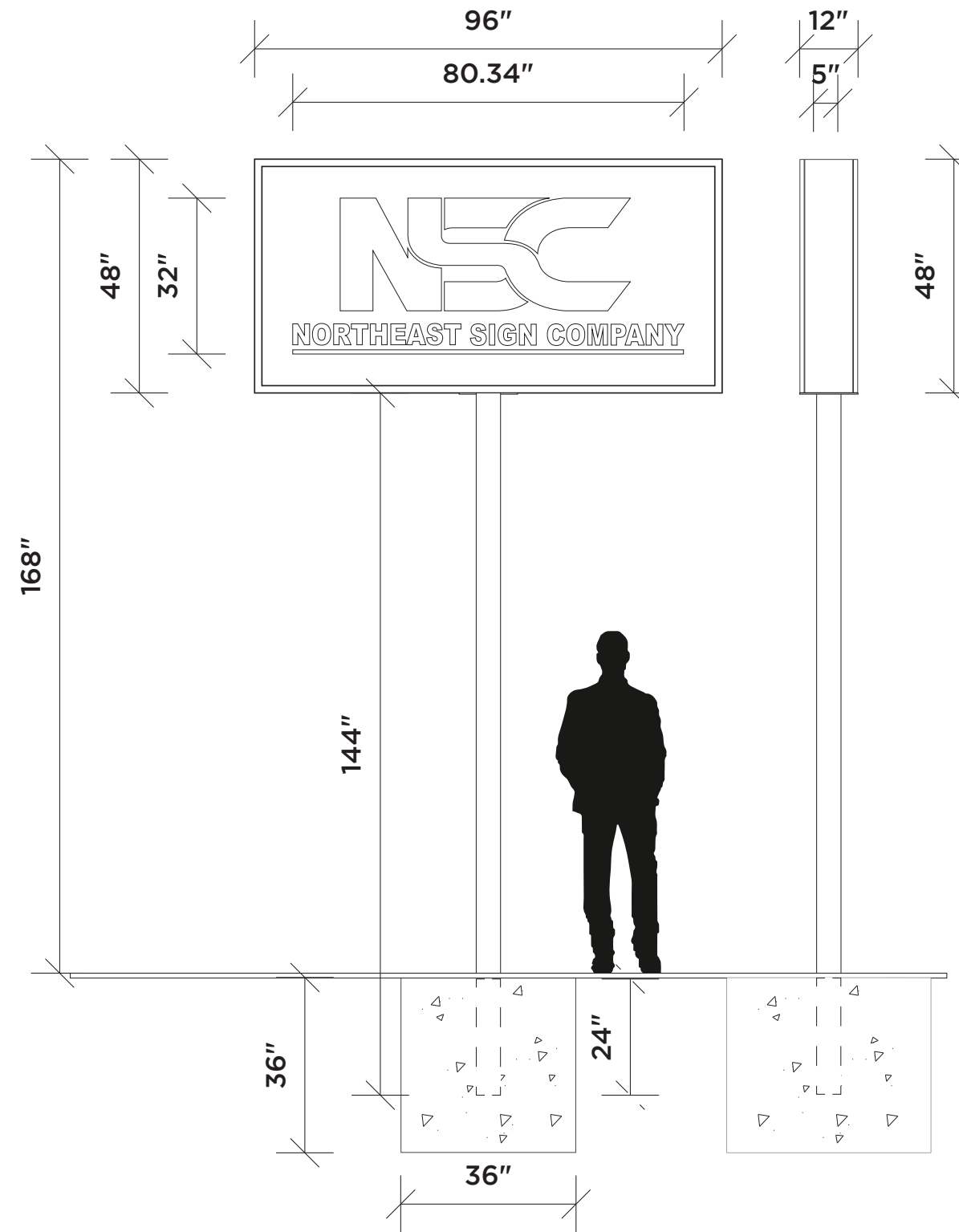

INSTALL ADDRESS:  
27 Dodge Avenue,  
North Haven, CT



ORDER NUMBER: 9510

## DESCRIPTION:

Pylon double-sided, with illuminated cabinet with vinyl application.

## DIMENSIONS:

96"(W) x 168"(H) x 12"(D)  
112 SQ FT

## EXAMPLE:

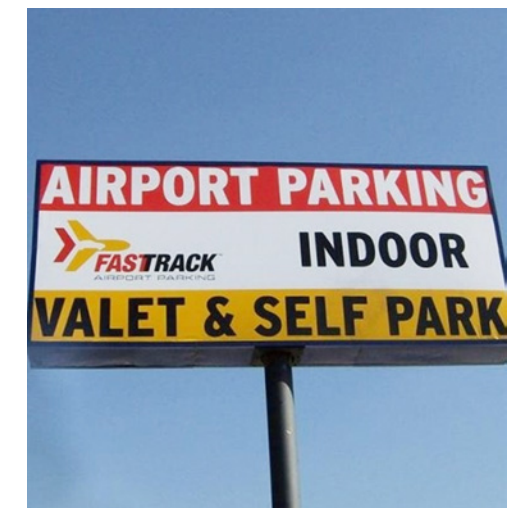

## CONTACT INFO:

Beth Tabriz  
beth.tabriz@northeastsigncompany.com  
503.884.7267  
northeastsigncompany.com

# NSC SQUARE/PYLON OVERVIEW

## FRONT VIEW BY DAY



## DETAIL BY NIGHT



ORDER NUMBER: 9510

## DESCRIPTION:

Pylon double-sided, with illuminated cabinet with vinyl application.

## DIMENSIONS:

96"(W) x 168"(H) x 12"(D)  
112 SQ FT

## DETAIL BASE

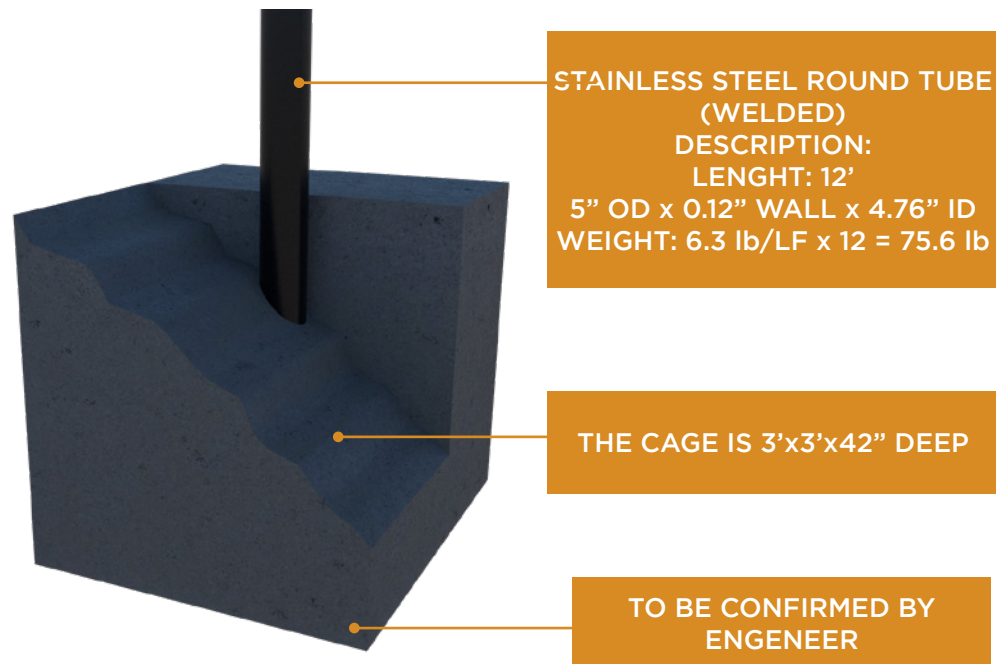

## PERSPECTIVE BY DAY



## FACE COLORS:



## EXAMPLE:

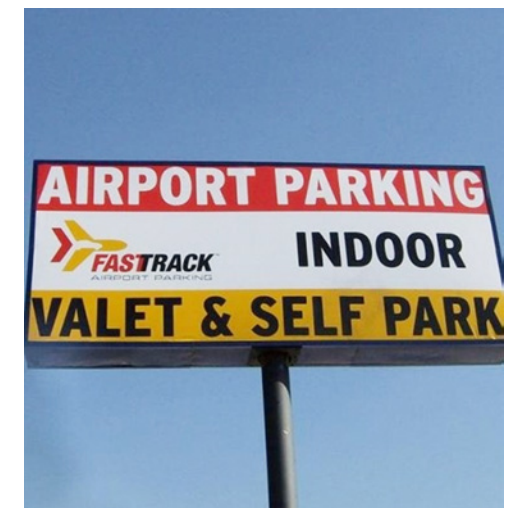

## CONTACT INFO:

Beth Tabriz  
beth.tabriz@northeastsigncompany.com  
503.884.7267  
northeastsigncompany.com